

MEDIUM POWER AMPLIFIER

ADVANCE DATA

- SILICON EPITAXIAL PLANAR NPN TRANSISTORS
- MINIATURE PLASTIC PACKAGE FOR APPLICATION IN SURFACE MOUNTING CIRCUITS
- GENERAL PURPOSE MAINLY INTENDED FOR USE IN MEDIUM POWER INDUSTRIAL APPLICATION AND FOR AUDIO AMPLIFIER OUTPUT STAGE
- PNP COMPLEMENT IS STZTA92

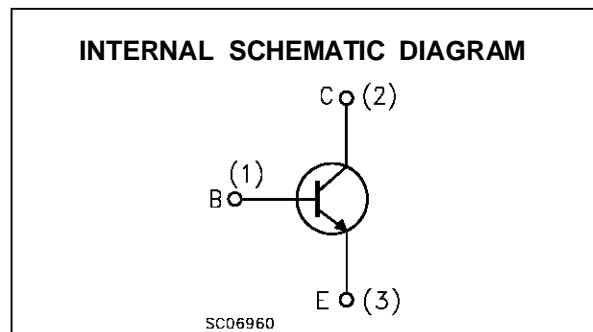
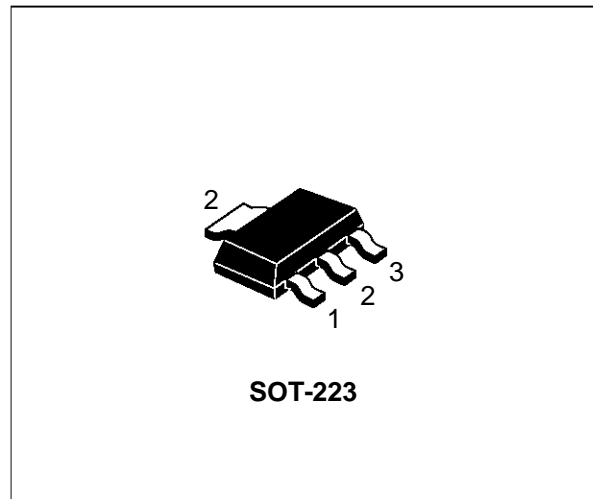

ABSOLUTE MAXIMUM RATINGS

Symbol	Parameter	Value	Unit
V_{CBO}	Collector-Base Voltage ($I_E = 0$)	300	V
V_{CEO}	Collector-Emitter Voltage ($I_B = 0$)	300	V
V_{EBO}	Emitter-Base Voltage ($I_C = 0$)	6	V
I_C	Collector Current	0.1	A
I_{CM}	Collector Peak Current	0.3	A
P_{tot}	Total Dissipation at $T_c = 25^\circ\text{C}$	2	W
T_{stg}	Storage Temperature	-65 to 150	$^\circ\text{C}$
T_j	Max. Operating Junction Temperature	150	$^\circ\text{C}$

STZTA42

THERMAL DATA

$R_{thj-amb}$ •	Thermal Resistance Junction-Ambient	Max	62.5	$^{\circ}\text{C}/\text{W}$
$R_{thj-tab}$ •	Thermal Resistance Junction-Collector Tab	Max	8	$^{\circ}\text{C}/\text{W}$

• Mounted on a ceramic substrate area = 30 x 35 x 0.7 mm

ELECTRICAL CHARACTERISTICS ($T_{case} = 25^{\circ}\text{C}$ unless otherwise specified)

Symbol	Parameter	Test Conditions	Min.	Typ.	Max.	Unit
I_{CBO}	Collector Cut-off Current ($I_E = 0$)	$V_{CB} = 200\text{ V}$			100	nA
$V_{(BR)CBO}$	Collector-Base Breakdown Voltage ($I_E = 0$)	$I_C = 100\ \mu\text{A}$	300			V
$V_{(BR)CEO}^*$	Collector-Emitter Breakdown Voltage ($I_B = 0$)	$I_C = 1\text{ mA}$	300			V
$V_{(BR)EBO}$	Emitter-Base Breakdown Voltage ($I_C = 0$)	$I_E = 100\ \mu\text{A}$	6			V
$V_{CE(sat)}^*$	Collector-Emitter Saturation Voltage	$I_C = 20\text{ mA}$ $I_B = 2\text{ mA}$			0.5	V
$V_{BE(sat)}^*$	Base-Emitter Saturation Voltage	$I_C = 20\text{ mA}$ $I_B = 2\text{ mA}$			0.9	V
h_{FE}^*	DC Current Gain	$I_C = 1\text{ mA}$ $V_{CE} = 10\text{ V}$ $I_C = 10\text{ mA}$ $V_{CE} = 10\text{ V}$ $I_C = 30\text{ mA}$ $V_{CE} = 10\text{ V}$	25 40 40			
f_T	Transition Frequency	$I_C = 10\text{ mA}$ $V_{CE} = 20\text{ V}$ $f = 50\text{ MHz}$	50			MHz
C_{CEO}	Collector Emitter Capacitance	$V_{CE} = 20\text{ V}$ $f = 1\text{ MHz}$	50			pF

* Pulsed: Pulse duration = 300 μs , duty cycle $\leq 1.5\%$

SOT223 MECHANICAL DATA

DIM.	mm			mils		
	MIN.	TYP.	MAX.	MIN.	TYP.	MAX.
a	2.27	2.3	2.33	89.4	90.6	91.7
b	4.57	4.6	4.63	179.9	181.1	182.3
c	0.2	0.4	0.6	7.9	15.7	23.6
d	0.63	0.65	0.67	24.8	25.6	26.4
e1	1.5	1.6	1.7	59.1	63	66.9
e4			0.32			12.6
f	2.9	3	3.1	114.2	118.1	122.1
g	0.67	0.7	0.73	26.4	27.6	28.7
l1	6.7	7	7.3	263.8	275.6	287.4
l2	3.5	3.5	3.7	137.8	137.8	145.7
L	6.3	6.5	6.7	248	255.9	263.8

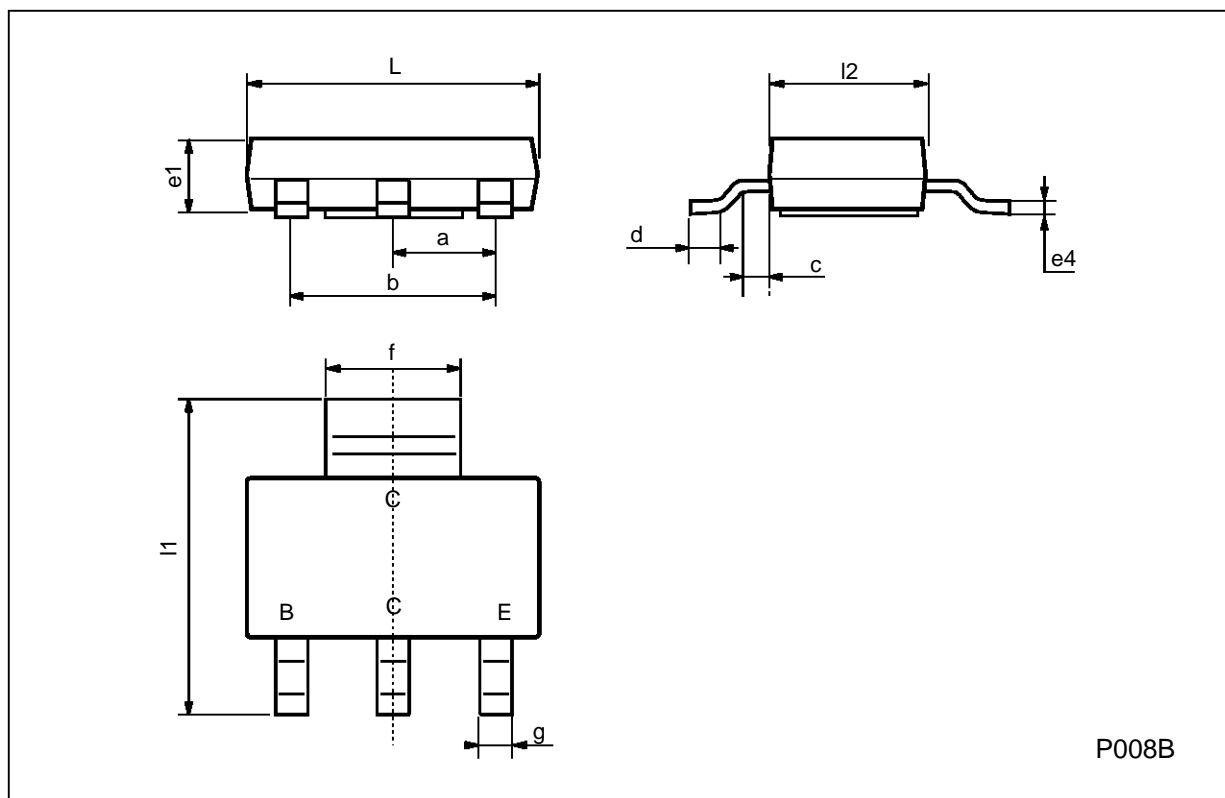

Information furnished is believed to be accurate and reliable. However, SGS-THOMSON Microelectronics assumes no responsibility for the consequences of use of such information nor for any infringement of patents or other rights of third parties which may result from its use. No license is granted by implication or otherwise under any patent or patent rights of SGS-THOMSON Microelectronics. Specifications mentioned in this publication are subject to change without notice. This publication supersedes and replaces all information previously supplied. SGS-THOMSON Microelectronics products are not authorized for use as critical components in life support devices or systems without express written approval of SGS-THOMSON Microelectronics.

© 1995 SGS-THOMSON Microelectronics - All Rights Reserved

SGS-THOMSON Microelectronics GROUP OF COMPANIES

Australia - Brazil - France - Germany - Hong Kong - Italy - Japan - Korea - Malaysia - Malta - Morocco - The Netherlands -
Singapore - Spain - Sweden - Switzerland - Taiwan - Thailand - United Kingdom - U.S.A